

## QUALITY INSPECTION SYSTEM

### ArgoCheck-31

The ArgoCheck from Pattyn Bakery Division is a unique quality control system dedicated to bakery and puff-pastry products. Easy to use and highly flexible, checks all types of product and sorts the bad products among the good ones.



### Maximize your reliability and accuracy

- **100% quality control** of each product at high speed.
- Very compact **3 in 1 system**: Metal check, dimensional control & emergency exit.
- Better reliability and consistency with **3D scanning technology** with possible height control.

3 different versions to select the level of rejection accuracy:

- S: "Entry level", rejection by one retracting belt possible, collateral rejection.
- D: "Mid-level", rejection by two retracting belts, reduced collateral rejection.
- M: "Accurate solution", rejection by multi retracting belts, perfect tracking and rejection selection.



Watch our videos  
at [pattyn.com](http://pattyn.com)

# TECHNICAL SPECIFICATIONS ARGOCHECK-31

## Controls of the products:

- Metal detection.
- Geometrical control such as length, width, dissymmetry, height...
- "Aspects control" (baking, scarification) as an option.

## Rejection module:

- Set of selecting doors to reject products in different containers according to the type of defect.
- Machine width: 860, 1000, 1200 or 1400 mm.

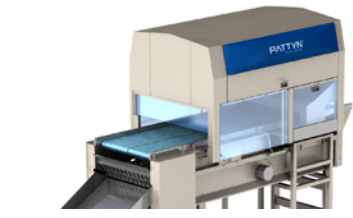
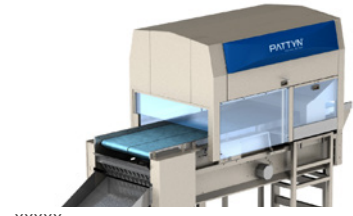
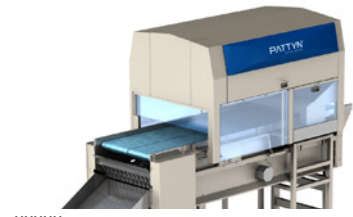

CONTAINER SPECIFICATIONS (For other dimensions, please contact Pattyn)	
Type	Cases, ...
Range (L x W x H // D) mm	Min. 300 (L) x 200 (W) x 150 (H) // 250 (D) Max. 730 (L) x 300 (W) x 400 (H) // 650 (D)
	Outside dimensions
CAPACITIES AND CONSUMPTION	
Capacities	Up to 13.000 baguettes/hour Up to 26.000 half bags/hour Up to 100.000 small products/hour
Installed power	xxx kW
Voltage	3 x 400 V + N + E / 50 Hz
Air supply	6 bar / 1/2" min
Air consumption	yy NI/cycle
Weight	xxx kg
CONSTRUCTION	
Stainless steel construction	
Servo driven retracting belts	
Vision dome with camera(s) and laser source(s)	
Argo scan vision calculator	
OPTIONS (More options are available, please contact Pattyn)	
Standalone version	
Large rejection bin	
Marks & Spencer version	
Automatic sample collection	
"Aspects" control (baking, scarification)	
Price depreciation for "a machine without Vision"	
Price depreciation for "a machine without MD"	

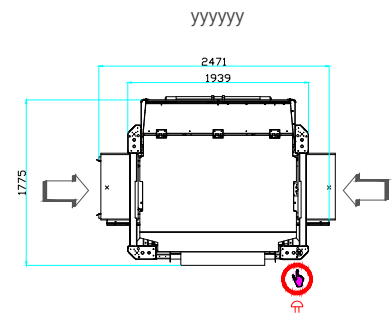

Machine height yyyy mm

Pattyn Bakery Division SAS  
ZA De Marcouly  
12350 Maleville - France

T +33 5 65 65 19 05  
info@pattyn.com  
www.pattyn.com



The description, pictures and information given have an indicative value. We reserve the right to make changes without notice. Information and content is property of Pattyn. For customised executions please contact Pattyn. ArgoCheck-31 2017 - V01

**PATTYN**<sup>®</sup>

Turnkey solutions for industrial packaging.