

## BAGMAKER INSERTER FLEXIM-41

From a roll of polyethylene film, the high performance Flexim-41 automatically makes, cuts and inserts bags into cases, crates, trays, tins or pails. The Flexim-41 is **standard equipped with fully automatic format change.**

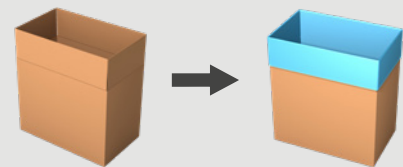

LOWEST  
PACKAGING COST  
USING BAGS  
FROM A REEL

### Minimize your bag cost

- **Save up to 30%** with made-to-measure bags from a reel.
- **Less film used** thanks to a perfectly controlled bag insertion.
- PE film starting from **10 µm**.

### High performance & trouble-free production

- Up to **22 cases/minute**.
- Up to 4000 bags on one reel for **higher autonomy**.
- **Elimination of operator mistakes** thanks to the fully automatic format change.
- Quick and **ergonomic film roll exchange** from the operator side.
- **15" HMI** to facilitate operator convenience



Watch our videos  
at [pattyn.com](http://pattyn.com)

# TECHNICAL SPECIFICATIONS FLEXIM-41

## Leakproof bag

- Impulse sealing for a controlled, clean and leakproof seal.

## Failsafe bag opening

- Innovative gripper and spoon module.
- Patented smart film opening technology with a special vacuum and air insertion system.

## Perfectly controlled bag insertion

- Case flap holders for perfect case flap positioning.
- Smart box lift for vertical box positioning.

## Use of stepper motor technology

- High speed.
- Self-resolving.

## Standard equipped with:

- 15" HMI for easy operation.
- Maintenance free V-shaped guillotine knife for a perfect film cut.
- Remote Access Point (one per line).

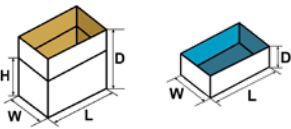
CONTAINER SPECIFICATIONS (For other dimensions, please contact Pattyn)	
Type	Cases, boxes, trays, crates, tins, pails, polystyrene cases, ...
Range [L x W // D] mm	<b>Multi or mono footprint (LxW) / variable heights</b> Min. 300 (L) x 200 (W) x 100 (D) [crates] Min. 300 (L) x 200 (W) // 260 (D) [cases]* Max. 800 (L) x 500 (W) // 650 (D)
	Outside dimensions * When combining cases and crates, the minimum height D = 260 mm * Cross seal unit 45° on both sides of the bag (150 mm < D < 460 mm)
*170 mm < D < 250 mm	Adapted bag cuff
*D < 170 mm	Modified box lift necessary
FILM SPECIFICATIONS	
Type	Tubular film with gussets (side folds)
Thickness	As from 10 µm
Weight of film roll	Max. 60 kg
Outside diameter film roll	Max. 450 mm
Inside diameter of core	76 mm
OUTPUT AND CONSUMPTION	
Output	Standard up to 14 c/min
Installed power	4,5 kW
Installed power with cross seal unit	6 kW
Voltage	3 x 400 V + N + E / 50 Hz
Air supply	6 bar / 1/2" min
Air consumption	60 NI / cycle
Weight	900 kg
OPTIONS (More options are available, please contact Pattyn)	
Fast machine: 14 to 18 c/min High speed servo: 18 to 22 c/min	Mechanical / Visual bag-in-box detection
Advanced stainless steel execution	Random case height modus
Film roll trolley	Flaps down modus
Cross seal unit to provide leakproof block bottom bag	
<b>Thermo transfer printer for real time printing on bags (traceability)</b>	
One line sealing - double sided heating	
Integrated air plunger for improved bag positioning	

Pattyn Belgium nv  
Industriepark 'Blauwe Toren'  
Hoge Hul 2, 8000 Brugge - Belgium

T +32 (0) 50 450 480  
info@pattyn.com  
www.pattyn.com

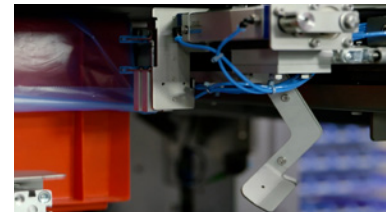

Innovative gripper and spoon module



Case flap holders



Controlled bag insertion



Optional thermo transfer printer



Optional corner seal unit 45°

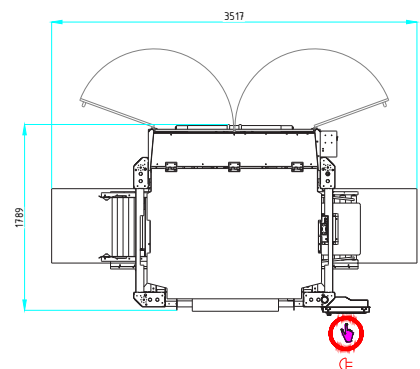

Machine height with door closed 2144 mm  
Machine height with door open 2804 mm

The description, pictures and information given have an indicative value. We reserve the right to make changes without notice. Information and content is property of Pattyn. For customised executions please contact Pattyn.