

BAG INSERTER ZIM-31

From a roll of polyethylene film, the compact ZIM-31 automatically inserts bags into boxes, crates or trays.

The bag inserter runs with **made-to-measure bags** or **pre-made bags from a 12 kg reel** and handles multi box footprints.

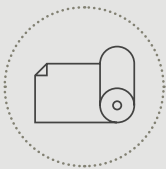
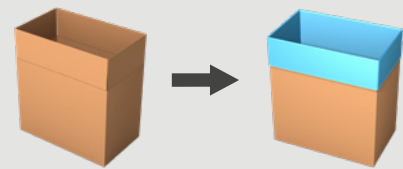

made-to-measure
bags from a reel

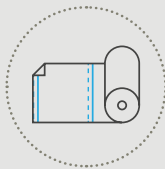

pre-made bags
from a reel

SOF
seal off first



Case lining convenience

- Continuous production thanks to the **automatic film roll exchange**.
- Super **compact**: only 1,7 x 1,3 m floor space needed.
- **15" HMI** to facilitate operator convenience.

Your intelligent bag inserter

- **Up to 14 cases/minute**.
- Quick and **ergonomic film roll loading**.
- **Patented smart film opening technology**.



Watch our videos
at pattyn.com

TECHNICAL SPECIFICATIONS

ZIM-31

Made-to-measure bags from a reel

- Continuous tubular gusseted film on a reel.
- Impulse sealing for a controlled and clean seal.

Pre-made bags from a reel

- Pre-sealed and perforated bags on a reel for optimal convenience.

Failsafe bag opening

- New strong gripper and spoon module.
- Patented smart film opening technology with a special vacuum and air insertion system.

Perfectly controlled bag insertion

- Case flap holders for perfect case flap positioning.
- Servo driven up and down movement of the gripper frame for a steady and smooth operation.

Operator friendly design

- Good maintenance accessibility.
- Improved interface with 15" HMI to facilitate operator convenience.

Standard equipped with:

- 15" HMI.
- Remote Access Point (one per line).
- Infeed conveyor with separator.



New strong gripper and spoon

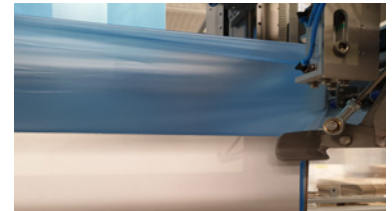

Case flap holders



Automatic film roll exchange



15" HMI

CONTAINER SPECIFICATIONS (For other dimensions, please contact Pattyn)

Type	Boxes, trays and crates
Range [L x W // D] mm	Outside case dimensions: L x W x H (D) mm (H = Flaps closed, D = Flaps up) Min. 300 (L) x 200 (W) // 100 (D) [crates] Min. 300 (L) x 200 (W) // 250 (D) [cases] (*) Max. 610 (L) x 410 (W) // 650 (D) (*) When combining cases and crates the minimum height D=250 mm Outside dimensions

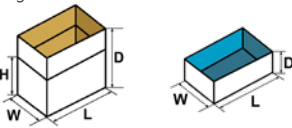

FILM SPECIFICATIONS

Type	Tubular film with gussets
Thickness	As from 15 µm
Weight of film roll	Max. 12 kg
Outside diameter film roll	Max. 230 mm
Inside diameter of core	76 mm

OUTPUT AND CONSUMPTION

Output	Standard up to 8 c/min (Depending on case sizes)
Installed power	4,5 kW
Voltage	3 x 400 V + N + E / 50 Hz
Air supply	6 bar / 1/2" min
Air consumption	45 NI / cycle
Weight	650 kg

OPTIONS (More options are available, please contact Pattyn)

Automatic format change	Advanced stainless steel execution
Thermo transfer printer	Air plunger for improved bag positioning
MAX footprint (800x600)	
Fast machine: 8 to 14 cases/minute	

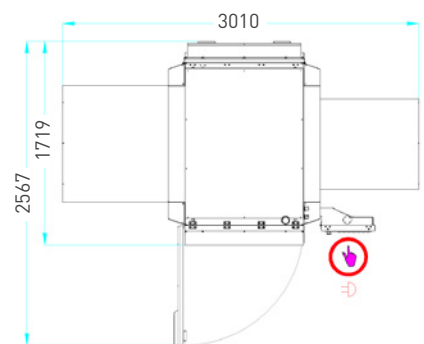

Machine height with film roll door closed: 2095 mm

Machine height with film roll door open: 2255 mm

Pattyn Belgium nv
Industriepark 'Blauwe Toren'
Hoge Hul 2, 8000 Brugge - Belgium

T +32 (0) 50 450 480
info@pattyn.com
www.pattyn.com



The description, pictures and information given have an indicative value. We reserve the right to make changes without notice. Information and content are property of Pattyn. For customised executions please contact Pattyn.