

# PATTYN®

## LINEAR VIBRATORY WEIGHFILLER LVF-34A-D

The LVF-34A-D linear vibratory filler with one head offers the most suitable solution to weigh and fill fragile products requiring low drop height such as **small IQF fruits and vegetables, dried fruit and candy.**

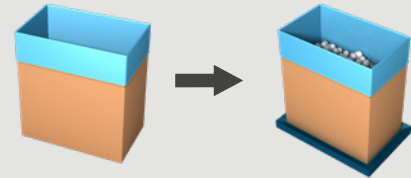

COMBINE  
CONVENIENCE  
WITH LOW DROP  
HEIGHT

### Easy to use, easy to clean

- Your ideal solution for **easy weigh filling** up to 5 c/min.
- Hygienic design.
- **Quick & easy cleaning** for minimum down-time.

### Gentle product treatment

- Gross filling straight **into the box** reduces **drop height and number of drops.**

 Watch our videos  
at [pattyn.com](http://pattyn.com)

# TECHNICAL SPECIFICATIONS LVF-34A-D

## Easy weigh filling

- Linear vibratory filler with 3 vibrating pans: one for taking the product out of the bunker, one big pan for coarse filling and one small pan for fine dosing.
- Constant product flow during fine filling.
- Product overflow from small vibrating pan to coarse filling pan.
- Weighing on a scale underneath the carton.

## Gross filling straight into the box

- Reduces drop height & number of drops
- Prevents product from sticking in a weigh hopper

## Fine dosing in separate weigh hopper

- For minimum after-fall.

## For fragile bulk products up to 2.4 x 2.4 x 2.4 inches

- IQF fruits like raspberries ...
- IQF vegetables
- Dried fruits
- Candy
- ...

## Standard equipped with

- Colour touch panel for easy operation.
- Remote access point (one per line).



Coarse and fine filling



Fine dosing in separate weigh hopper for minimum after-fall.

LVF-34 A-D

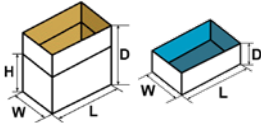
CONTAINER SPECIFICATIONS [For other dimensions, please contact Pattyn]	
Type	Cases, trays, plastic crates ...
Range (L x W // D) mm	Min. 12" (L) x 8" (W) // 4" (D) Max. 31 1/2 (L) x 19 1/2 (W) // 25 1/2 (D)
	Outside dimensions
OUTPUT AND CONSUMPTION	
Output	Up to 5 c/min (depending on product and weight)
Product diameter size	Max. 2.4 x 2.4 x 2.4 inches
Installed power	4,6 kW
Voltage	3 x 480 V + E / 60 Hz
Air supply	90 PSI, (1/8" min)
Air consumption	0.04 ft <sup>3</sup> / cycle
Weight	1543 lbs
OPTIONS (More options are available, please contact Pattyn)	
Dimple plate execution	
Heating element to prevent condensation	

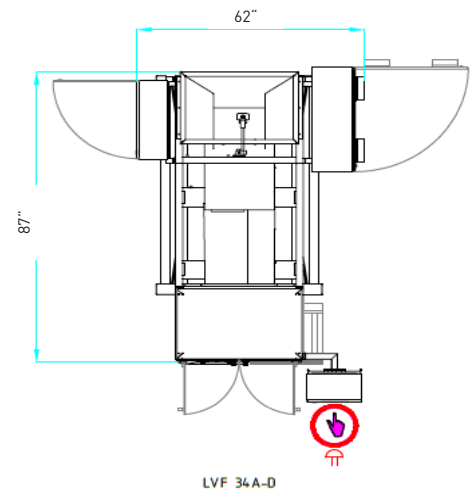

LVF 34A-D

Left handed version  
(right handed version also possible)

Machine height 96 inches

Machine height as reference only,  
depending on case dimensions.

**Accuracy depends on the product and capacity.  
For more details or specific requirements, please contact us.**

Pattyn North America Inc.  
N76 W30500 County Road Vv  
Hartland, WI. 53029 - U.S.A

Ph +1 262-966-0300  
Fax +1 262-966-0312  
SalesUsa@pattyn.com



The description, pictures and information given have an indicative value. We reserve the right to make changes without notice. Information and content is property of Pattyn. For customized executions please contact Pattyn. LVF-34A-D 2021 - V01

**PATTYN**<sup>®</sup>

Turnkey solutions for industrial packaging.