

BULK FILLING STATION MEC-12

Designed to handle a large range of fragile products, the bulk filling station MEC-12 is an economic, fast and effective solution compatible with a wide range of boxes.

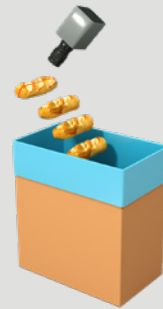

GENTLE
HANDLING
AT HIGH SPEED



Gentle handling

- Two hoppers to **minimize product drop**
- **Hoppers designed with soft materials** to receive products
- Box lift
- Three filling modes for a **wide range of products and boxes flexibility**

High speed and efficiency

- **Various configurations available**
- **Up to 20 boxes/min**
- Rejection door to guide product flow to a container **in the event of fault**
- Access through **wide opening doors**
- **Very easy to clean**
- **Compact machine**



Watch our videos
at pattyn.com

TECHNICAL SPECIFICATIONS MEC-12

2 versions (see capacities)

- boxes up to 15.7" x 11.8"
- boxes up to 23.6" x 15.7" (large hopper version)

Hygienic design

- Open frame design for easy cleaning and maintenance.

3 working modes

- **Single drop:** hopper buffer the batch of products to fill the box at once.
- **Double drop:** between drops, the box is moved forward to have an optimised repartition.
- **Fast drop:** configurable sequence to increase speed (increases the overall drop height)

Easy box positioning

- Easy box width adjustment.
- Roller guides mounted on spring system for box width compensation (+/- 5 mm).

Recipe

- Box lift system: automatic positioning defined by recipes.

Reject mode

- Automatic product rejection in separated container (200L) in case of fault.

Standard with

remote access point (one per line)



Box lift system to reduce drop distance

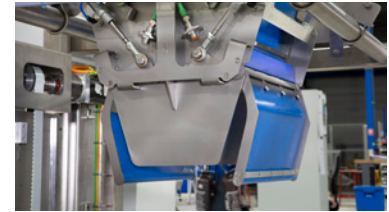

Soft hopper material



Easy box adjustment

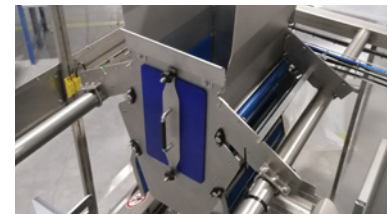

Opening door to the hoppers for cleaning access

CAPACITIES			
	Single drop	Double drop	Fast drop
all types of products 	Up to 12 boxes / min	Up to 10 boxes / min	Up to 20 boxes / min
BOX SIZES			
	Length	Width	Height (flaps open)
Min	11.8" / 15.7" with large hopper version	7.8" / 11.8" with large hopper version	11.8" / 17.7" with large hopper version
Max	24"	16"	24.2"
CONSUMPTION			
Installed power	2 kW	Voltage	3 x 400 V + E / 50 Hz
Air supply	6 bar/ 90PSI	Air consumption	105 NI / min
CONSTRUCTION			
Stainless steel construction			
Open frame			
Weight 1102 lbs			
OPTIONS (More options available, please contact Pattyn France)			
Machine delivered with specific infeed /outfeed (modified protection tunnel)			
Box width self-adjustment			
adaptable with plastic crates (conditions to be defined)			
Box width up to 18"			

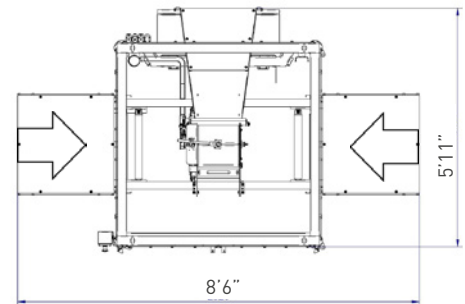

MEC-12 Machine height 6'5" to 8'2"

Across configuration

Aligned configuration

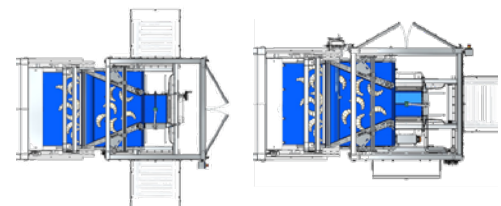

Pattyn
ZI de la Glèbe - 314 Rue de la murette
12200 SAVIGNAC - France

T +33 5 65 65 19 05
info@pattyn.com
www.pattyn.com



The description, pictures and information given have an indicative value. We reserve the right to make changes without notice. Information and content is property of Pattyn. For customised executions please contact Pattyn. MEC-12 2022 - V01

PATTYN®

Turnkey solutions for industrial packaging.