

## CASE ERECTOR CE-31

The case erector CE-31 forms cases with length up to 29 inches. The performance of the CE-31 is also guaranteed when handling boxes with minimal carton thickness. Standard in hot melt execution, also available in tape execution.

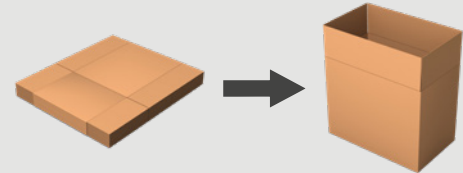

COMBINE WITH  
**THE BAGMAKER  
INSERTER**

### Minimize your running cost

- Trouble-free case erecting even with **thin cartons**.
- Lower running cost and continuous production with hot melt.
- **15" HMI** to facilitate operator convenience.

### Designed to be better

- **No more crushed cartons** thanks to the perfectly controlled case erecting.
- Guaranteed **box squareness** for a trouble-free packaging process.
- Only **5 adjustments** for a quick format change.



Watch our videos  
at [pattyn.com](http://pattyn.com)

# TECHNICAL SPECIFICATIONS

## Perfectly controlled case erecting

- The failsafe carton separator separates each carton individually from the magazine thanks to the unique up & down separation movement.
- Two opposing vacuum cups grip the blank at two sides for optimal carton opening.
- Less demanding on the box quality because the box is clamped at three sides during case flap folding.

## Perfectly squared box

- The synchronised chain guiding system ensures a perfectly squared box.

## Guaranteed closed bottom

- Downwards spraying of the nozzles, eliminates the risk of clogging.
- Two separate mechanical plungers for perfect bonding.

## CE-31 hot melt is standard equipped with:

- 15" HMI and multicolour warning light.
- Nordson hot melt device
- Hot melt nearly finished: hot melt level detection enables refilling before hot melt is completely empty.
- Remote access point (one per line)

## CE-31 tape is standard equipped with

- 15" HMI and multicolour warning light.
- Remote access point (one per line).

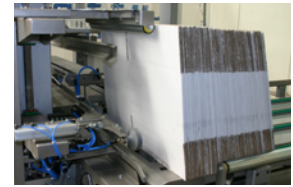

Failsafe carton separator



Box is clamped at three sides



Synchronised chain system

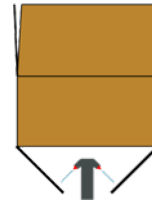

Hot melt unit

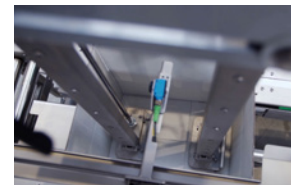

Two separate mechanical plungers for perfect bonding

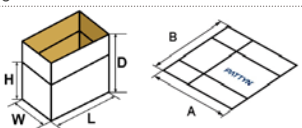
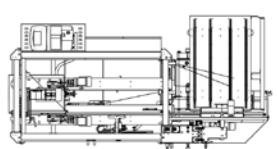
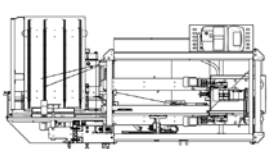
CASE DIMENSIONS [For other dimensions, please contact Pattyn]	
Range [L x W x H // D] inches	Min. 12" (L) x 8" (W) x 6" (H) // 10" (D) Max. 28 ¾" (L) x 19 ½" (W) x 15 ¾" (H) // 25 ½" (D)
Range [A x B] inches	Min. 20" (A) x 14" (B) Max. 43" (A) x 35 ½" (B)
	Length – height relation: D/L < 1,3 Outside dimensions
TAPE SPECIFICATIONS	
Type	2" inch
Tape roll length	3248 ft
Tape roll diameter	Max. 11.8"
TECHNICAL FEATURES	
Left 	Right 
OUTPUT AND CONSUMPTION	
Output hot melt	Standard up to 16 c/min, upgradeable to 20 c/min
Output tape	Standard up to 12 c/min, upgradeable to 16 c/min
Installed power hot melt	7 kW
Installed power tape	2,5 kW
Voltage	3 x 480 V + E / 60 Hz
Air supply	90 PSI, (1/2" min)
Air consumption	1.2 ft <sup>3</sup> / cycle
Weight	2535 lbs
OPTIONS (more options are available, please contact Pattyn)	
Longer carton magazine: 40"	3" tape
Advanced stainless steel execution	Multiple carton magazines
Ergonomic tape exchange with second taping head	

CE-31 Hot melt

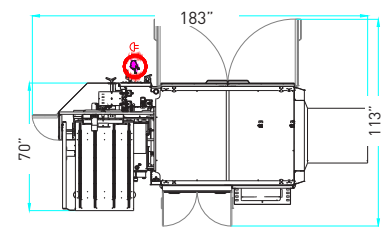

CE-31 Tape

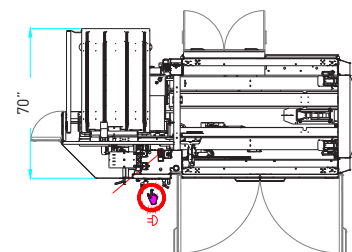

Machine height 94 inches

Pattyn North America Inc.  
N76 W30500 County Road Vv  
Hartland, WI. 53029 - U.S.A

Ph +1 262-966-0300  
Fax +1 262-966-0312  
SalesUsa@pattyn.com



The description, pictures and information given have an indicative value. We reserve the right to make changes without notice. Information and content is property of Pattyn. For customized executions please contact Pattyn. CE-31 2022 - V01