

CASE CLOSER CC-31

The CC-31 automatically folds the top case flaps and closes them with tape. To maximize operator convenience, the software of the case closer is integrated in the bag closer.

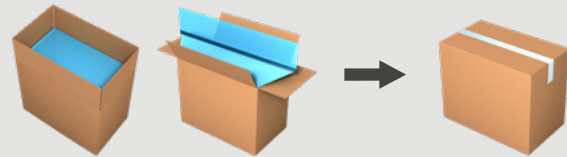

INTEGRATED IN THE
THE BAG
CLOSER

Industrial Design to avoid production stops

- **Floating taper head** (optional).
- **Heavy duty machine for a reliable production 24/7.**
- **Standard robust taper head** with open design for easy tape exchange.

Protect your product & reduce costs

- **Perfectly controlled** case closing thanks to the pneumatic driven long flap folding.
- **High-quality components** reduce maintenance and spare parts costs to a minimum.
- **Easy adjustable with motor driven height regulation.**



Watch our videos
at pattyn.com

TECHNICAL SPECIFICATIONS

Perfectly controlled case closing

- Case stop for rear flap folding.
- Pneumatic driven folding plates for long flap folding.
- The long case flaps are joined perfectly thanks to lateral wheels.
- Flexible side belts ensuring the same grip, even if the box width slightly varies.

Heavy duty

- Direct motor driven side belts, driven by 2 motors.
- Heavy duty machine frame with easy access for maintenance.

Standard integrated in the bag closer to save floor space

- Visualize all messages in the bag closer HMI.
- The case closer is completely controlled by the bag closer.
- One integrated safety area.
- One centralised operator panel.
- One power supply.

Standard equipped with

- In- and outfeed guarding.
- Access point for remote support (one per line).
- Adjustable box pressing before taping.

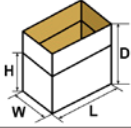
CASE SPECIFICATIONS (For other dimensions, please contact Pattyn)	
Range (L x W x H) inches	Min. 10 ½" (L) x 8" (W) x 5" (H) // 9" (D) Max. 25 ½" (L) x 20 ½" (W) x 20 ½" (H) // 30 ½" (D)
	Outside dimensions
TAPE SPECIFICATIONS	
Type	2" tape
Tape roll length	3248 ft
Tape roll diameter	Max. 11.8"
OUTPUT AND CONSUMPTION	
Output tape	Standard 18 cases/minute
Installed power	1 kW
Voltage	3 x 480V + E / 60 Hz
Air supply	90 PSI, (½" min)
Air consumption	0.1 ft³ / cycle
Weight	1653 lbs
OPTIONS (more options are available, please contact Pattyn)	
Stainless steel execution	
3" tape	
Complete detection set tape	
Flaps control section	
Bottom belt drive for pails	
Stand-alone machine	
15" HMI (for stand-alone machine)	
Floating taper head	
Machine roof	



Pneumatic driven long flap folding

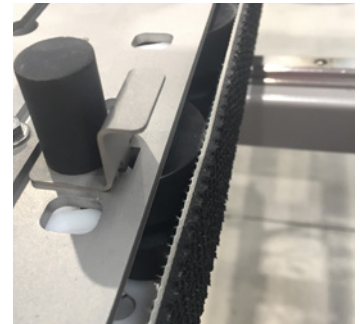

Flexible side belts



Robust side belts, driven by 2 motors



Easy tape loading system for upper taper

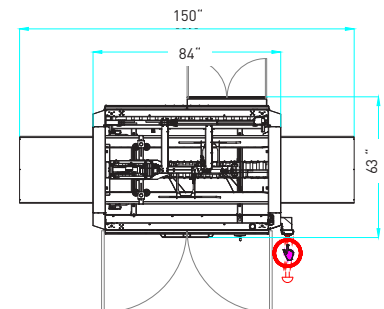

Machine height: 82"

Pattyn North America Inc.
N76 W30500 County Road Vv
Hartland, WI. 53029 - U.S.A

Ph +1 262-966-0300
Fax +1 262-966-0312
SalesUsa@pattyn.com



The description, pictures and information given have an indicative value. We reserve the right to make changes without notice. Information and content is property of Pattyn. For customized executions please contact Pattyn. CC-31 2021 - V01

PATTYN[®]

Turnkey solutions for industrial packaging.