

COMBINED BAG INSERTER, HOPPER & BAG SEALER ULTIM 21-S

The ULTIM-21-S combines 3 units in only one machine: a bag inserting unit, product receiving unit with integrated hopper and bag sealing unit.

This monobloc machine offers the most suitable solution to pack bulk solids and semi-liquid products (such as fish, meat, fruit, vegetables,..) into low trays or plastic crates. The products need to be dropped automatically at one filling position.

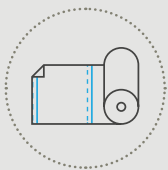
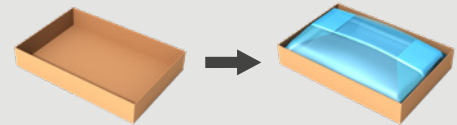

pre-made bags
from a reel

SOF
seal off first



Outfeed conveyor
not included

COMBINE
WITH ANY KIND OF
FILLING STATION

Protect your product in a sealed bag

- Automatically lines low containers and ensures **perfectly closed bags**
- Hygienic design: **hose down**
- **Lowest guaranteed running cost** using PE film from 0.6 mils

Combine bag inserting & sealing

- 3 units in one machine for **easy operation**
- **Compact** footprint
- Up to 8 c/minute
- **Continuous production** thanks to the **automatic film roll exchange**

TECHNICAL SPECIFICATIONS ULTIM-21-S

Pre-made bags from a reel

- Use of pre-made bags for optimal running in hose down cleaning environments

Developed for 24/7 reliable operation

- Bag opening by mechanical grippers instead of delicate vacuum cups
- Bag presence is checked before filling
- Chain system with hooks to keep film up during filling

Product receiving station with hopper

- The integrated hopper is used as an interface to synchronize the ULTIM-21-S with any kind of filling station (such as a linear weigh filler, multi-head filler, batcher, pick & place unit,...)
- Especially for the meat industry, the hopper can be replaced by a filling nozzle for automatic MDM filling.

Double sided impulse heat sealing

- After filling the bag is regusseted and top sealed to ensure 100% product protection

Hygienic design

- For hose down cleaning
- Demountable hopper with quick release for easy cleaning

ULTIM 21-S is standard equipped with

- Vacuum system (removal of excess air with vacuum probe).
- Colour touch panel for easy operation.
- Remote access point (one per line).

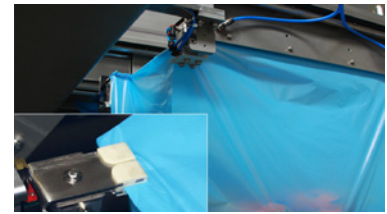

Mechanical grippers



Demountable hopper for easy cleaning



ULTIM-21-S with filling nozzle

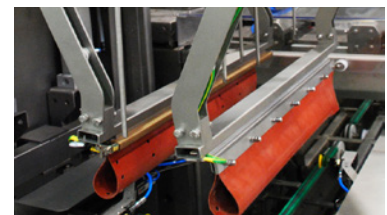

Top seal module: bag regussetting and sealing



Automatic film roll exchange

CONTAINER SPECIFICATIONS (FOR OTHER DIMENSIONS, PLEASE CONTACT PATTYN)	
Type	Carton trays, plastic crates
Range (L x W // D) inches	Mono footprint (L x W) / variable heights
	Min. 15 3/4" (L) x 12" (W) // 3 1/4" (D)
	Max. 23 3/4" (L) x 15 3/4" (W) // 10" (D)
	Outside dimension
FILM SPECIFICATIONS	
Type	Tubular film with gussets
Thickness	As from 0.6 mil – 1.4 mil
Weight of film roll	Max. 26 1/2 lbs
Outside diameter film roll	Max. 9 inches
Inside diameter of core	3 inches
OUTPUT AND CONSUMPTION	
Output	Up to 8 c/min
Installed power	13 kW
Voltage	3 x 480 V + E / 60 Hz
Air supply	90 PSI, (1/2" min)
Air consumption	2.2 ft ³ / cycle
Weight	4189 lbs
OPTIONS (More options are available, please contact Pattyn)	
Automatic film roll exchange	
Perforation below top seal for easy bag opening without knife	

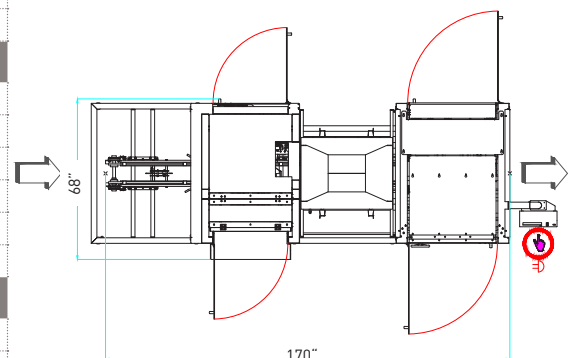

Machine height: 84 inches

Pattyn North America Inc.
N76 W30500 County Road Vv
Hartland, WI. 53029 - U.S.A

Ph +1 262-966-0300
Fax +1 262-966-0312
SalesUsa@pattyn.com



The description, pictures and information given have an indicative value. We reserve the right to make changes without notice. Information and content is property of Pattyn. For customized executions please contact Pattyn. ULTIM-21-S 2021 - V01

PATTYN[®]

Turnkey solutions for industrial packaging.