

## COMBINED BAG INSERTER, HOPPER & BAG SEALER ULTIM 21-S

The ULTIM-21-S combines 3 units in only one machine: a bag inserting unit, product receiving unit with integrated hopper and bag sealing unit.

This monobloc machine offers the most suitable solution to pack bulk solids and semi-liquid products (such as fish, meat, fruit, vegetables,...) into low trays or plastic crates. The products need to be dropped automatically at one filling position.

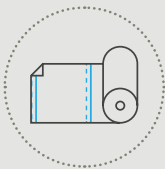
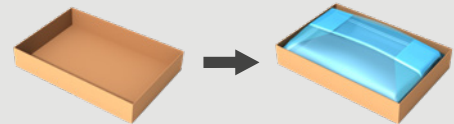

pre-made bags  
from a reel

SOF  
seal off first



Outfeed conveyor  
not included

COMBINE  
WITH ANY KIND OF  
FILLING STATION

### Protect your product in a sealed bag

- Automatically lines low containers and ensures **perfectly closed bags**
- Hygienic design: **hose down**
- **Lowest guaranteed running cost** using PE film from 15 µm

### Combine bag inserting & sealing

- 3 units in one machine for **easy operation**
- **Compact** footprint
- Up to 8 c/minute
- **Continuous production** thanks to the **automatic film roll exchange**



Watch our videos  
at [pattyn.com](http://pattyn.com)

# TECHNICAL SPECIFICATIONS ULTIM-21-S

## Pre-made bags from a reel

- Use of pre-made bags for optimal running in hose down cleaning environments

## Developed for 24/7 reliable operation

- Bag opening by mechanical grippers instead of delicate vacuum cups
- Bag presence is checked before filling
- Chain system with hooks to keep film up during filling

## Product receiving unit with integrated hopper

- The integrated hopper is used as an interface to synchronize the ULTIM-21-S with any kind of filling station (such as a linear weigh filler, multi-head filler, batcher, pick & place unit,...)
- Especially for the meat industry, the hopper can be replaced by a filling nozzle for automatic MDM filling.

## Double sided impulse heat sealing

- After filling the bag is regusseted and top sealed to ensure 100% product protection

## Hygienic design

- For hose down cleaning
- Demountable hopper with quick release for easy cleaning

## ULTIM 21-S is standard equipped with

- Vacuum system (removal of excess air with vacuum probe)
- Colour touch panel for easy operation
- Remote Access Point (one per line)



Mechanical grippers



Demountable hopper for easy cleaning



ULTIM-21-S with filling nozzle

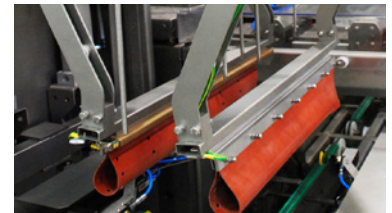

Top seal module: bag regussetting and sealing

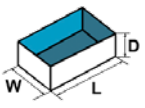

Automatic film roll exchange

CONTAINER SPECIFICATIONS (FOR OTHER DIMENSIONS, PLEASE CONTACT PATTYN)	
Type	Carton trays, plastic crates
Range (L x W // D) mm	<b>Mono footprint (L x W) / variable heights</b>
	Min. 400 (L) x 300 (W) // 80 (D)
	Max. 600 (L) x 400 (W) // 250 (D)
	Outside dimensions
FILM SPECIFICATIONS	
Type	Tubular film with gussets
Thickness	As from 15 µm up to 35 µm
Weight of film roll	Max. 12 kg
Outside diameter film roll	Max. 230 mm
Inside diameter of core	76 mm
OUTPUT AND CONSUMPTION	
Output	Up to 8 c/min
Installed power	13 kW
Voltage	3 x 400V + N + E / 50Hz
Air supply	6 bar / 1/2" min
Air consumption	60 NI / cycle
Weight	1900 kg
OPTIONS (More options are available, please contact Pattyn)	
Automatic film roll exchange	
Perforation below top seal for easy bag opening without knife	

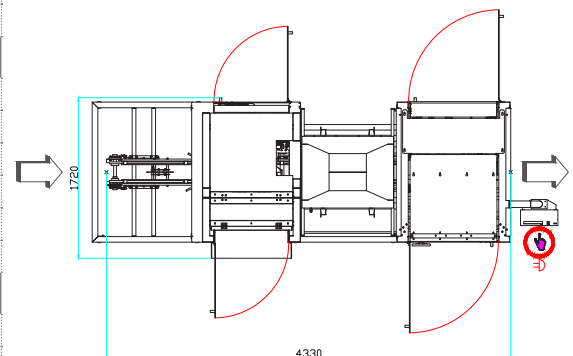

Machine height 2126 mm

Pattyn Packing Lines nv  
Industriepark 'Blauwe Toren'  
Hoge Hul 2, 8000 Brugge - Belgium

T +32 (0) 50 450 480  
info@pattyn.com  
www.pattyn.com



The description, pictures and information given have an indicative value. We reserve the right to make changes without notice. Information and content is property of Pattyn. For customised executions please contact Pattyn. ULTIM-21-S 2021 - V01

**PATTYN**<sup>®</sup>

Turnkey solutions for industrial packaging.