

BAG DECUFFER SEALER DS-31

The **compact** DS-31 automatically decuffs, stretches and heat seals the bag.

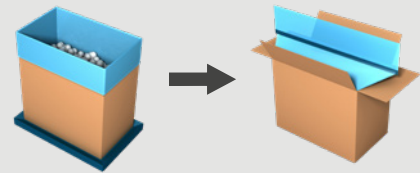

COMBINE WITH
**THE CASE
CLOSER**

Protect your product

- The DS-31 guarantees a **perfect seal** to avoid contact between the product and carton.
- Thanks to the servo controlled movement, the DS-31 safeguards the quality of the liner.
- Minimal moving parts above the filled case.

Maximize your productivity

- Up to **15** cases/minute.
- **Big box range.**
- Quick format change.
- Maximum uptime by design and interconnectivity.
- **15"** HMI to facilitate operator convenience.



Watch our videos
at pattyn.com

TECHNICAL SPECIFICATIONS

Perfect seal

- Improved stretcher movement ensures lower impact on case flaps.
- Intelligent stepper driven stretchers for correct film tension and tension release before sealing.
- Impulse heat sealing from both sides.
- Decuffer control for film detection (optional).
- Dust-free vacuum decuffing for maximum food safety (optional).

High speed

- Heavy duty roller conveyor and adjustable stopper system.
- Servo driven up and down movement of the sealing frame.

Hygienic balcony design, easy to clean

- Cleaning mode: to facilitate an improved cleaning accessibility.

Equipped with:

- 15" HMI for easy operation
- remote access point (one per line)
- Mechanical bag decuffing



Vacuum bag decuffing (optional)

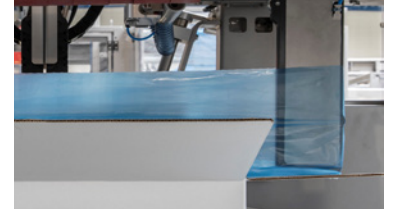

Decuffer control (optional)



Bag leakproof sealing

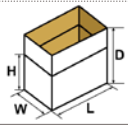
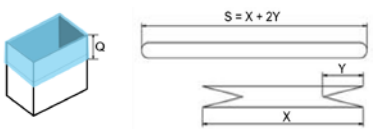

15" HMI

| CONTAINER SPECIFICATIONS (For other dimensions, please contact Pattyn) | |
|---|---|
| Type | Cases, trays |
| Range (L x W x H // D) mm | Multi footprint Min. 300 (L) x 200 (W) x 100 (H)* Max. 650 (L) x 410 (W) // 650 (D) * Trays minimum height 200 mm |
|  | Outside dimensions |
| FILM SPECIFICATIONS | |
| Type | PE (LDPE, HDPE) |
| Thickness | As from 10 µm |
|  | $S = L + 15$ $Y = (W + 25) / 2$ $S = \max 1080 \text{ mm}$ $L + W + 40 \leq S \leq L + W + 90$ $140 \leq Q \leq 180 \text{ mm}$ |
| OUTPUT AND CONSUMPTION | |
| Output | Up to 15 c/min Up to 13 c/min for oils & fats |
| Installed power | 7,5 kW |
| Voltage | 3 x 400 V + N + E / 50 Hz |
| Air supply | 6 bar / 1/2" min |
| Air consumption | 30 NI/cycle |
| Weight | 800 kg |
| OPTIONS (More options are available, please contact Pattyn) | |
| Perforation module | |
| Retractable stretcher plates | |
| Decuffer control on regussetting bars for film detection | |
| Automatic format change | |
| Vacuum bag decuffing | |

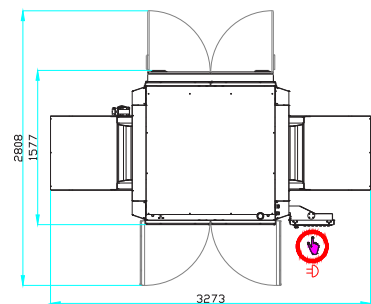

Machine height 2384 mm

Pattyn Packing Lines nv
Industriepark 'Blauwe Toren'
Hoge Hul 2, 8000 Brugge - Belgium

T +32 (0) 50 450 480
info@pattyn.com
www.pattyn.com



The description, pictures and information given have an indicative value. We reserve the right to make changes without notice. Information and content is property of Pattyn. For customised executions please contact Pattyn. DS-31 2021 - V01

PATTYN[®]

Turnkey solutions for industrial packaging.