



SEMI-LIQUIDS



Polybag lining solutions to pack and weighfill semi-liquids, oils & boxed fats

Complete packaging lines

Pattyn Packing Lines offers you fully and semi-automated lines to pack and fill oils & fats, ranging from 5 to 30 kg. Flexibility, reliability and accuracy are characteristic of our approach. It will be our pleasure to offer a solution tailored to your specific wishes.

Dedicated solutions for your oils & boxed fats

We provide you with easily adjustable weighfillers, guaranteeing the appropriate solution for your product, recipient and required filling capacity.

A wide range of different recipients

Our packaging machines handle all types of oils & fats. We pack them into a wide range of different recipients: polybag lined cases, tins, pails, drums, metal cans, ring containers...

Experience with different types of products

Pattyn Packing Lines has acquired considerable know-how in the packaging of various products and therefore guarantees the very best handling of your products :

- butter oil (AMF)
- palm oil
- palm kernel oil
- sunflower oil
- coconut oil
- peanut oil
- margarine
- minarine
- shortening
- cocoa butter
- cocoa butter substitute (CBS)
- specialty fats
- frying fats
- animal fats
- process cheese
- fondant sugar
- mayonnaise
- ...

More than 500 industrial companies worldwide are using a packaging solution of Pattyn Packing Lines



The semi-liquids line: how Pattyn Packing Lines guarantees the very best ha

A →

case erector

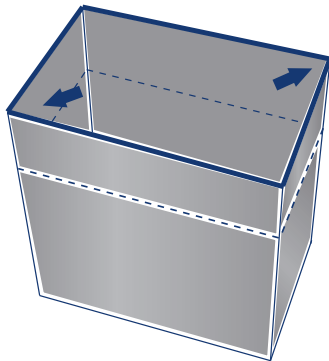

B →

bagmaker inserter

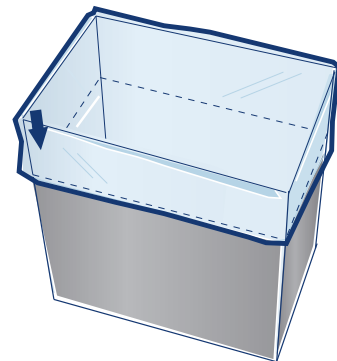

C →

filler

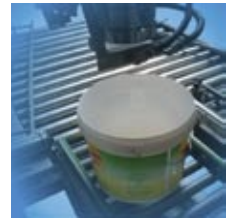
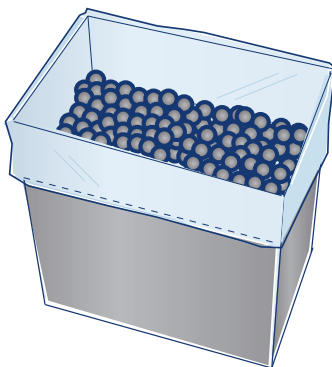

1. AVL-22 Weighfiller

Two heads weighfiller with two filling valves and scales, designed for continuous, accurate and gravimetric weighfilling of oils & fats.

- Up to 12 cases / minute
- Up and down mechanism for easy height adjustment
- Fast / slow system for maximum weight accuracy
- Standard deviation of only 15 gr.
- Jacketed filling system for consistent product flow

D →

bag folder or bag sealer

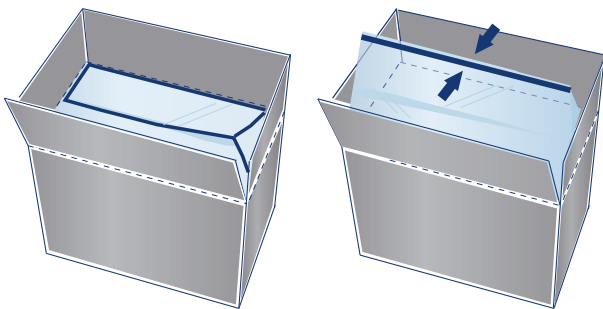

case closer

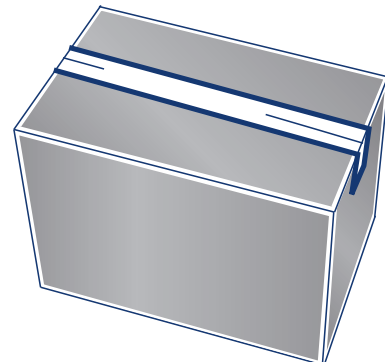



Flexim-21 Bagmaker inserter

- High production speed
- Fast and easy case format change
- Use of made-to-measure bags of a reel of polyethylene film
- Corner sealed and leakproof block bottom bags
- Failsafe bag opening
- Complete product protection from dust, dirt and humidity (HACCP)

**A failsafe system
providing maximum
cost-efficiency and
optimal hygiene**



2. AVL-24 Weighfiller

Four heads weighfiller with four filling valves and scales, designed for continuous, accurate and gravimetric weighfilling of oils & fats.

- Up to 16 cases / minute
- Up and down mechanism for easy height adjustment
- Fast / slow system for maximum weight accuracy
- Standard deviation of only 15 gr.
- Jacketed filling system for consistent product flow

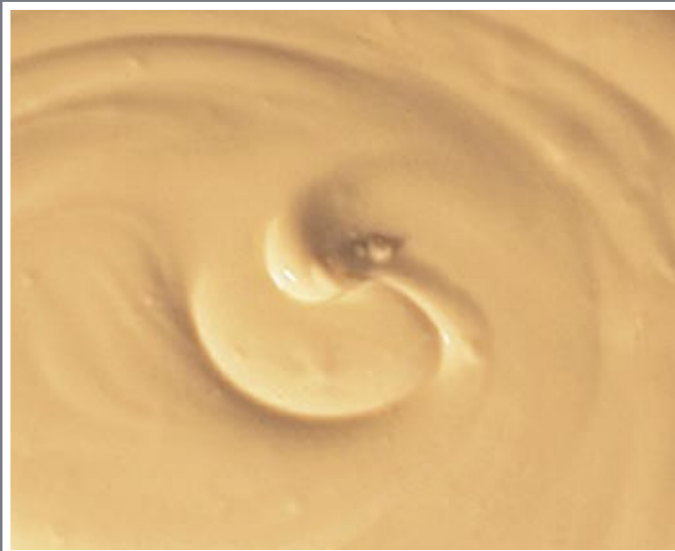

DF-11 Bag decuffer folder

- High speed
- Automated and perfect bag overlap folding
- High-quality components for easy operation
- Optional: integrated case closer



DS-11 Bag decuffer sealer

- High speed
- Automated and leakproof sealing on both sides of the bag
- Compact machine dimensions
- Optional: integrated case closer

References

Baeten & Co (Belgium)
 Vandemoortele (Belgium / Spain)
 AAK (Denmark / Sweden / UK / Mexico)
 ADM Pura Foods (UK)
 Gerkens Cacao (The Netherlands)
 ADM Cocoa (The Netherlands / Singapore)
 Walter Rau (Germany)
 Nordzucker (Germany)
 Ingra Brozzi (Italy)
 Unigra (Italy)
 Cargill (UK / Malaysia / USA)
 Moi Foods (Malaysia)
 JB Cocoa (Malaysia)
 PT Mikie Oleo Nabati (Indonesia)
 Liberty Oil Mills (India)
 Fuji Oils Pte (Singapore)
 Qinhuangdao Goldensea (China)
 Loders Croklaan (USA / Malaysia)
 Unilever Andina (Colombia)
 Sigra (Colombia)
 Industrial Aceitera (Mexico)
 Anchor (New Zealand)
 Murray Goulburn (Australia)
 ...

The benefits of Pattyn Packing Lines

- Cost-efficient solutions
- Individual packaging machines
- Complete polybag lining solutions
- Integrated and individual approach
- One-operator line
- Durable and fast machines
- Human Machine Interface
- Wide range of executions and options

Pattyn Packing Lines designs & manufactures easy-to-use packaging machines and complete lines to pack, weighfill and count products for industrial use. Benefit from our know-how, technology and customer service to be one step ahead in your sector of industry. **Discover more at: www.pattyn.com**

semi-liquids



frozen foods



caps & closures



parbaked
frozen bread



powder &
granulates



tobacco

