

one CAN MAKE A DIFFERENCE



## BAGMAKER INSERTER

From a roll of polyethylene film, the Flexim-31 automatically measures, cuts and inserts bags into cases, crates, trays, tins or pails.

**NEW!**  
automatic  
format  
change

FLEXIM-31



combine with the case erector  
**CE-11-P**

# FLEXIM-31

### MINIMIZE YOUR BAG COST

- > Save up to 30% with made-to-measure bags from a reel.
- > Reduce bag dimensions thanks to a perfectly controlled bag insertion.
- > PE film starting from 12 µm.

### HIGH PERFORMANCE

- > Up to 20 cases / minute.
- > 2000 bags on one reel for higher autonomy.
- > Fully automatic format change.
- > Quick and ergonomic film roll exchange from the operator side.

watch the video at [pattyn.com/na](http://pattyn.com/na)



frozen fish



preforms



powders & granulates



frozen bread



frozen food



semi-liquids



caps & closures



tobacco

# TECHNICAL SPECIFICATIONS



Mechanical grippers & spoons with air nozzle



Case flap holders



Controlled bag insertion



Optional thermo transfer printer

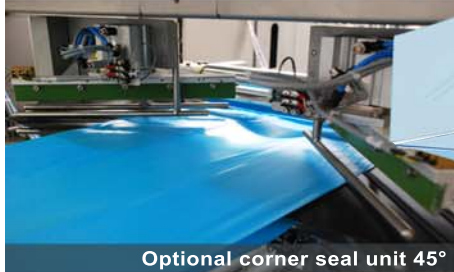

Optional corner seal unit 45°



## FLEXIM-31

### LEAKPROOF BAG

- > Impulse sealing for a controlled, clean and leakproof seal.

### FAILSAFE BAG OPENING

- > Mechanical grippers instead of delicate vacuum cups.
- > Standard ionization bar.

### PERFECTLY CONTROLLED BAG INSERTION

- > Case flap holders for perfect case flap positioning.
- > Spoons with integrated air nozzle for gentle cuffing.
- > Smart box lift for vertical box positioning.

### USE OF STEPPER MOTOR TECHNOLOGY

- > High speed.
- > Self-resolving.
- > Fully automatic format change.

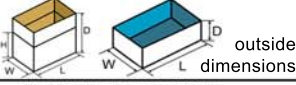
CONTAINER SPECIFICATIONS	
Type	cases, boxes, trays, crates, tins, pails, porex cases, ...
Range ( LxW // D) Inches	min. 11-13/16" (L) x 7-7/8" (W) // 3-15/16" (D) max. 31½" (L) x 19-11/16" (W) // 25-5/8" (D)
	cross seal unit 45° on both sides of the bag (5-7/8" < D < 18-1/8")*
*6-11/16" < D < 9-13/16"	Adapted bag cuff
*D < 6-11/16"	Modified box lift necessary
FILM SPECIFICATIONS	
Type	Tubular film with gussets (side folds)
Thickness	As from 12µm
Weight of film roll	max. 132 lbs.
Outside diameter film roll	max. 17¼"
Inside diameter of core	3 Inches
OUTPUT AND CONSUMPTION	
Output	Standard 14 c/min, up to 20 c/min
Installed power	4 Hp
Voltage	3 x 480V + E / 60Hz
Air supply	87 lbs/Inch <sup>2</sup> , (½" min)
Air consumption	2 ft <sup>3</sup> / cycle
Weight	1980 lbs.
OPTIONS (more options are available, please contact Pattyn Packing Lines)	
> Fast machine: speed above 14 to 20 c/min	
> All stainless steel	
> Cover placing	
> Film roll trolley	
> Mechanical control on bag presence	
> Cross seal unit to provide leakproof block bottom bag	
> Thermo transfer printer for real time printing on bags (traceability)	
> Integrated flaps down mechanism	
> One line of sealing, two active sides of sealing wire	
> Air plunger for wrinkle free case lining	

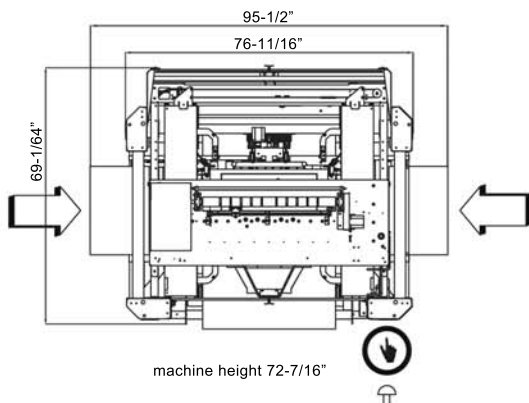

[pattyn.com/na](http://pattyn.com/na)

Pattyn North America, LLC / W300 N9083 CTY E / Hartland, WI 53029 / U.S.A. / Ph. +1 262 727 7040 / F +1 262 727 7137 / [info@pattyn.com](mailto:info@pattyn.com)

The description, pictures and information given have an indicative value. We reserve the right to make changes without notice. Information and content is property of Pattyn Packing Lines. For customised executions please contact Pattyn Packing Lines. Flexim 31 2011 - V01