

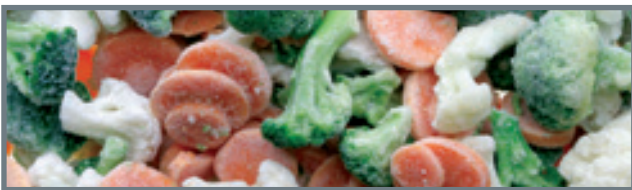

BULK PRODUCTS



Polybag lining solutions to pack, weigh and tumble fill food and non food products

Complete packaging lines

Pattyn Packing Lines offers you fully automated lines to pack, weigh and tumble fill frozen foods, dry & snack foods, caps & closures, PET preforms and paint powders ranging from 5 to 30 kg. Flexibility, reliability and accuracy are characteristic of our approach.

Dedicated solutions for your food or non food products

Pattyn Packing Lines integrates any kind of OEM weighfiller with its special designed Pattyn interface system, guaranteeing the appropriate solution for your specific product and required filling capacity.

Experience with different types of products

Pattyn Packing Lines has acquired a considerable know-how in the packaging of various products and therefore guarantees the very best handling of:

- frozen fruit & vegetables
- frozen potato products
- frozen or non-frozen fish
- frozen or non-frozen meat
- confectionary
- dried fruit
- snack food
- pasta
- caps & closures
- tubes
- components
- PET preforms
- paint powder
- ...

More than 500 industrial companies worldwide are using a packaging solution of Pattyn Packing Lines



How Pattyn Packing Lines guarantees the very best handling of your products

A → case erector

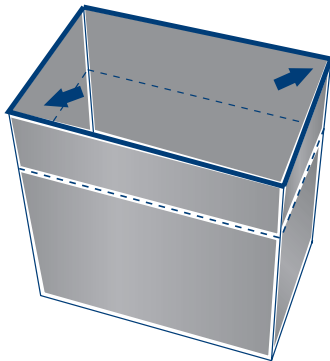

B → bagmaker inserter

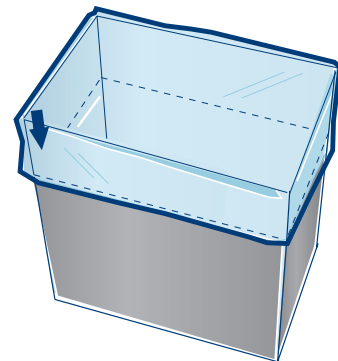

C → filler

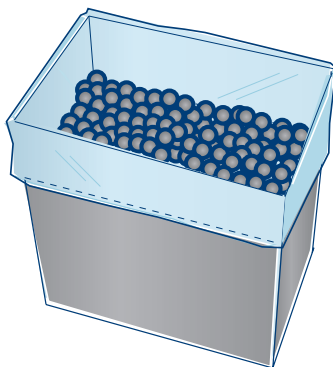

Coarse and fine filling

1. Pattyn weighfiller

Designed for continuous and accurate weighing, dosing and tumble filling of frozen fruits, frozen vegetables, chocolate products, ...

- Coarse and fine filling
- Easy to clean
- Stainless steel execution, clean and durable

D → bag folder or bag sealer

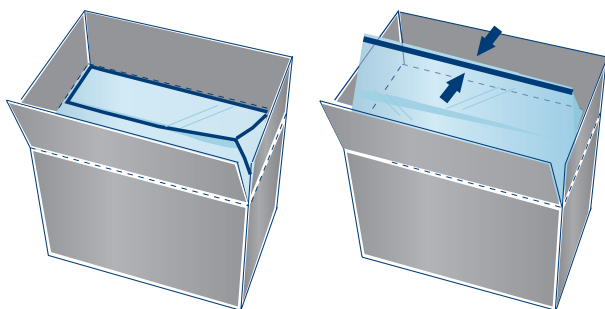

case closer

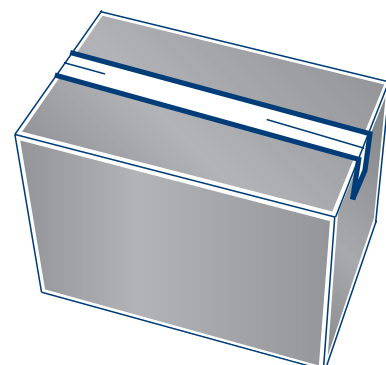



Flexim-21 Bagmaker inserter

- High production speed
- Use of a wide range of small and large cases, boxes, trays, crates,...
- Fast and easy format change
- Use of made-to-measure bags of a reel of polyethylene film
- Failsafe bag opening
- Complete product protection from dust, dirt and humidity (HACCP)

**A failsafe system
providing maximum
cost-efficiency and
optimal hygiene**



No product spillage

2. Flexible Pattyn interface system

Pattyn Packing Lines integrates any kind of OEM weighfiller, such as a multi-head or linear weigher, with its special designed Pattyn interface system.

- High speed solution
- Perfect bag placement during filling
- Limited drop level
- No product spillage

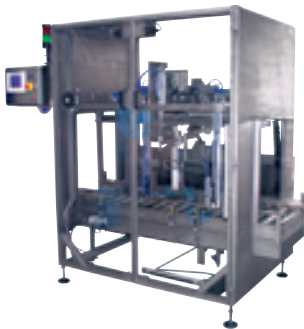

DF-11 Bag decuffer folder

- High speed
- Automated and perfect bag overlap folding
- High-quality components for easy operation



DS-11 Bag decuffer sealer

- High speed
- Automated and leakproof sealing on both sides of the bag
- Compact machine dimensions

References

Nestle / Herta (Germany)

Ardo (Belgium / France)

Hesbaye Frost (Belgium)

D'Arta (Belgium)

Pasfrost (Belgium)

Cooperl Hunaudaye (France)

IQF Fish Factory (Iceland)

Barry Callebaut (Belgium)

VOG Lavorazione Frutta (Italy)

Carpisa (Spain)

The Bama Companies (USA)

Ancor White Cap (Germany)

CMB Italcaps (Italy)

Technocap (Italy)

Adapta Powder Coatings (Spain)

Agraz (Spain)

Oxyplast (Belgium)

Varoise de concentrés / Coca Cola (France)

...

The benefits of Pattyn Packing Lines

- Cost-efficient solutions
- Individual packaging machines
- Complete polybag lining solutions
- Integrated and individual approach
- One-operator line
- Durable and fast machines
- Human Machine Interface
- Wide range of executions and options

Pattyn Packing Lines designs & manufactures easy-to-use packaging machines and complete lines to pack, weighfill and count products for industrial use. Benefit from our know-how, technology and customer service to be one step ahead in your sector of industry. **Discover more at: www.pattyn.com**

semi-liquids



frozen foods



caps & closures



parbaked
frozen bread



powder &
granulates



tobacco

